

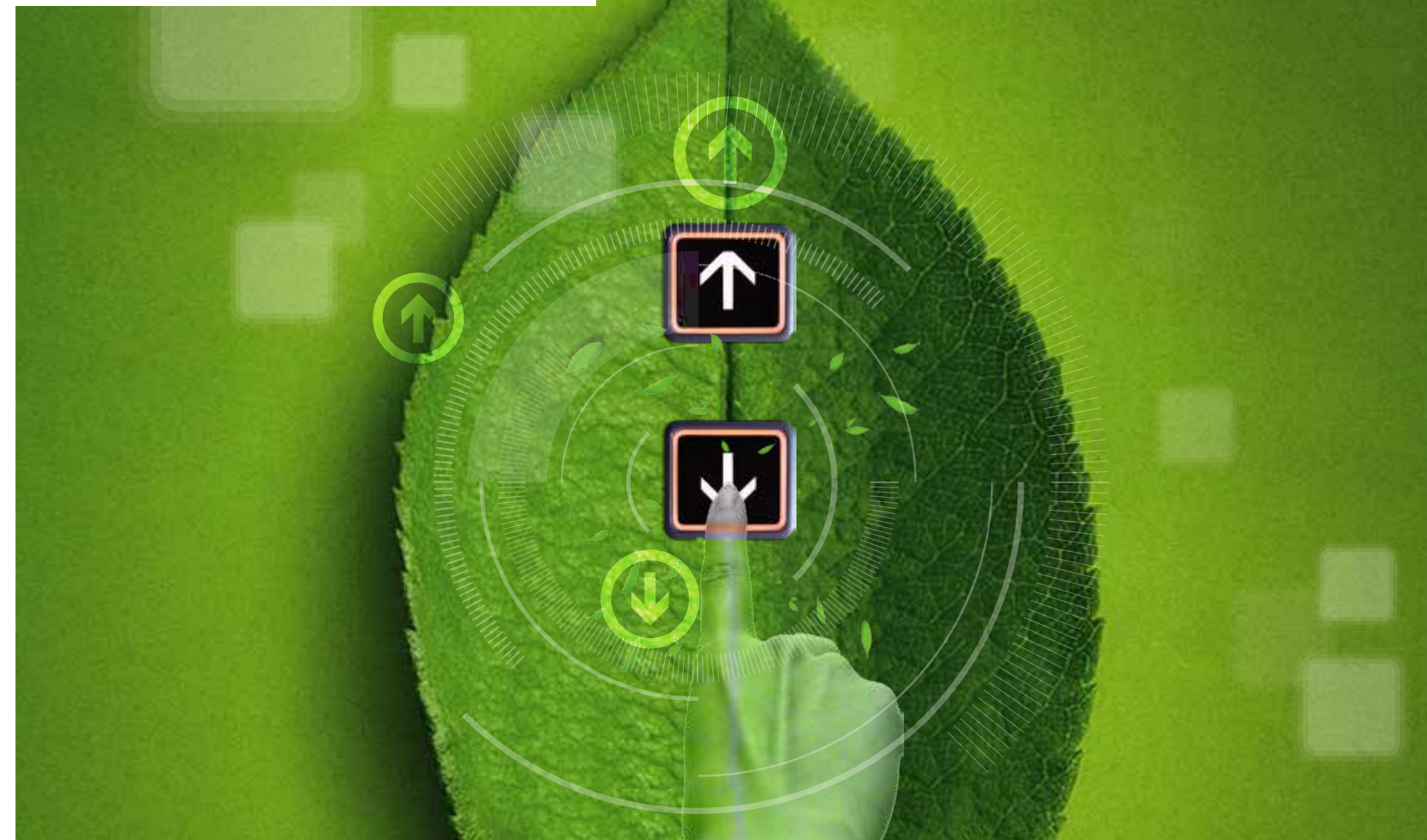

**宁波谷达机电有限公司**  
NINGBO GUDA MECHANICAL & ELECTRICAL CO.,LTD

工厂地址：宁波市鄞州区滨海创业中心鄞东南路221号 邮编 315145  
研发中心：鄞州区启明路818号创新128园区一幢9号 邮编 315105  
电话：0574-83088962 传真：0574-87805521-8962  
Q Q：2853731301 手机：138 0589 5340  
邮件：dht@nbguda.com  
网站：www.nbguda.com

Office: NO9 #1 Building,128 Innovation Park, NO.818 QiMing Road,  
YinZhou District, Ningbo, China.315105  
Tel: +86 574 87808536 FAX: +86 574 83088966  
Mobile: +86 1380 666 7395 Skype: winson.ge  
Email: winson@nbguda.com  
Webside: www.nbguda.com



**钢带无齿曳引机**

BELT GEARLESS TRACTION MACHINE

**2.0版本**





## COMPANY INTRODUCTION 公司介绍

宁波谷达机电有限公司，成立于2008年，集曳引机开发、制造、销售及服务为一体的新型企业。我们拥有专业的电梯人才，从业以来一直专注于钢带及其曳引机的研发与制造。

Since the establishment in 2008,Ningbo Guda M&E Co.,Ltd begins with R&D of gearless elevator tractor,have been developed into an integral enterprise,specializing in manufacturing,marketing and servicing.We get the cutting edge of professional engineers and technology support.







**CERTIFICATE**  
产品认证

# BELT-TYPE TRACTION MACHINE

**GUDA** 宁波谷达  
www.nb-guda.com  
**钢带曳引机**

# 10t

# 1



优化的电机设计，高效的曳引能力以及可采用更轻的轿厢使综合效率大幅提高。

Energy-saving: Optimized motor design, high efficiency of power conversion, suitable for light lift car.

# 2



采用包裹钢带，保护钢丝不被锈蚀，运行无需加油，节能环保。

Environmental friendly & low maintenance: Traction belt made of cladding steel cable to prevent from rust, and minor friction, work without lubricant.

# 3



永磁同步电机采用进口SKF轴承和德国HEIDHAIN编码器。

Smooth Operation: PM synchronous motor design, configured with Heidenhain Encoder, SKF bearings.

# 4



采用筒支梁结构，力学结构合理，空间布局美观。

Compact Structure: Compact traction system, more reasonable mechanical structure and space layout.

# 5



采用小轮轴径的曳引轮，反向轮，对重轮以及细长型的主机布置使井道投影面积更小。

Lesser liftway: Smaller sheave dia, and thinner design enable the traction machine to save space.

# 6



满足低顶层空间和无机房设计要求。

Meet the requirement of lesser head room and MRL design.

# 7



承重：320kg至2000kg，速度0.4m/s至2.0m/s。

Loading capacity : 320kg to 2000kg  
Speed : 0.4m/s to 2.0m/s





**GEARLESS TRACTION MACHINE SERIES**  
曳引机产品系列



**GDB112 series**



**GDB132 series**

Series Speed	Home Lift	Passenger Lift		
	Capacity	0.40 m/s	0.63 m/s	1.00 m/s
320 kgs	GDB112 series			
400 kgs				
480 kgs				
630 kgs		GDB132 series		
800 kgs				
1000 kgs				
1250 kgs				
1600 kgs				
2000 kgs				



# HOME Elevator Tractor

## 家用电梯专用曳引机

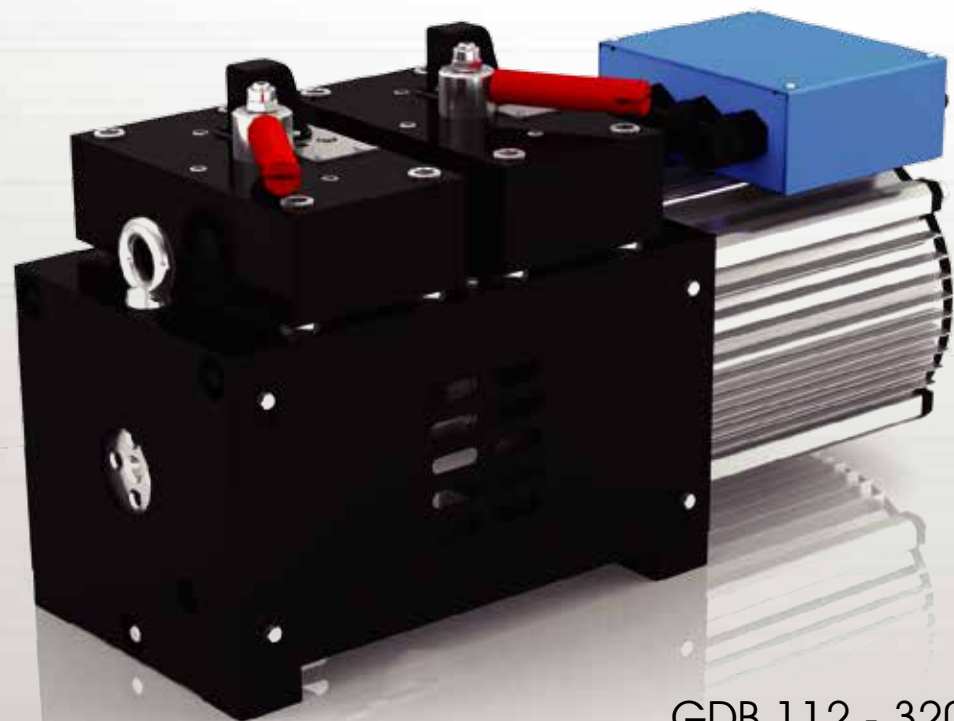

GDB 112 - 320  
GDB 112 - 400

载重 load: 320 / 400kg  
电源电压 Voltage: 220 / 380V  
悬挂比 Suspension: 2:1  
中心高 Center Height: 112mm  
自重 Weight: 85 / 90kg  
最大静态载荷 Max.Static Load: 2000kg  
制动器 Brake: DC198V 2\*0.18A  
or DC110V 2\*0.38A

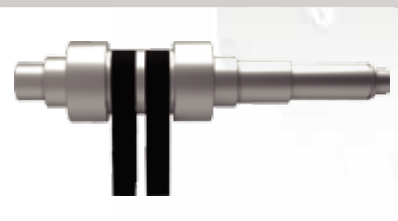

盘手车轮 (为选择项)  
HAND WHEEL (COULD BE OPTIONAL)

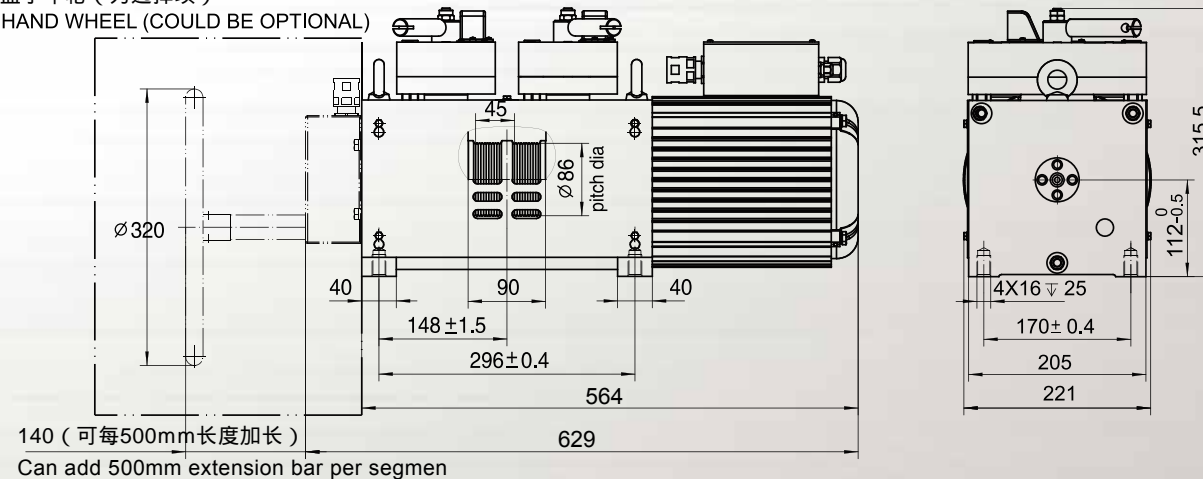

型号	TYPE	GDB112-320-4-12	GDB112-320-4-34	GDB112-400-4-12	GDB112-400-4-34
载重 Kg	Load capacity Kg	320	320	400	400
梯速 m/s	Lift speed m/s	0.4	0.4	0.4	0.4
额定功率 Kw	Rated power Kw	0.86	0.86	1.1	1.1
频率 Hz	Frequency Hz	11.9	11.9	11.9	11.9
额定转速 r/min	Rated speed r/min	178	178	178	178
额定转矩 N.m	Rated torque N.m	46	46	59	59
相数电压 V	Phase/Voltage V	1/220	3/380	1/220	3/380
额定电压 V	Rated Voltage V	168	314	171	308
电流 A	Current A	5.4	2.7	6.6	3.7
曳引轮节径 mm	Sheave dia mm	86	86	86	86
曳引带数量 NO.	Traction belt qty NO.	2	2	2	2
绝缘等级	INS.class	F	F	F	F
防护等级	IP Code	IP42	IP42	IP42	IP42
极数 P	Poles P	8	8	8	8

注：本机需选配专用曳引带，带扣组件，导向轮，另外可选配，松闸组件，盘车手轮组件。

Notes: GDB machine need to work with dedicated traction belt,belt lock& clip,pulley guide.Also,our hand wheel and brake release could be optional when auxiliary braking system is in need.

# PASSENGER Elevator Tractor

## 乘客电梯专用曳引机



GDB 112 - 320  
GDB 112 - 400

载重 load: 320 / 400kg  
电源电压 Voltage: 220 / 380V  
悬挂比 Suspension: 2:1  
中心高 Center Height: 112mm  
自重 Weight: 85 / 90kg  
最大静态载荷 Max.Static Load: 2000kg  
制动器 Brake: DC198V 2\*0.18A  
or DC110V 2\*0.38

盘手车轮 (为选择项)  
HAND WHEEL (COULD BE OPTIONAL)

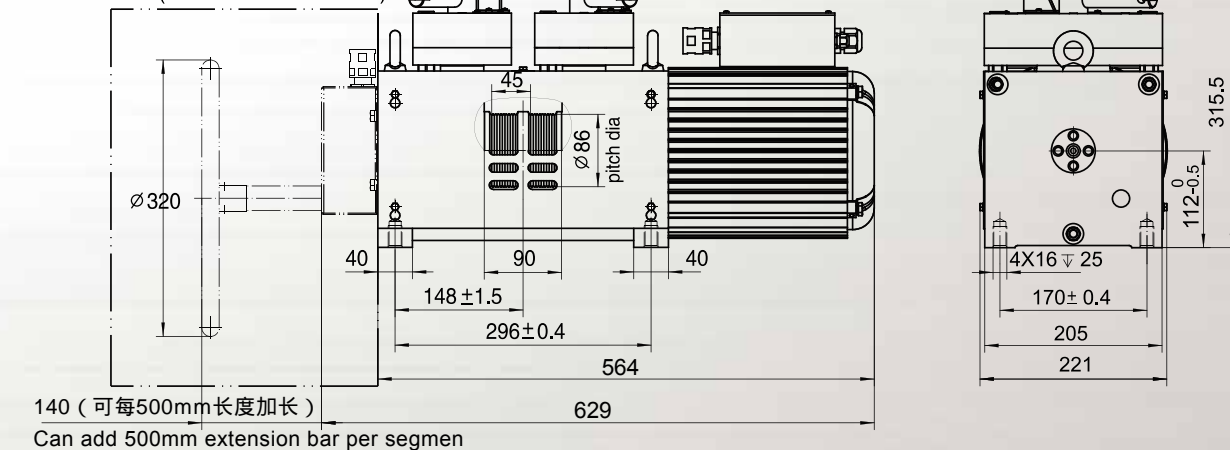

型号	TYPE	GDB112 -320-6.3-12	GDB112 -320-6.3-34	GDB112 -320-10-12	GDB112 -320-10-34	GDB112 -400-6.3-12	GDB112 -400-6.3-34	GDB112 -400-10-12	GDB112 -400-10-34
载重 Kg	Load capacity Kg	320	320	320	320	400	400	400	400
梯速 m/s	Lift speed m/s	0.63	0.63	1.0	1.0	0.63	0.63	1.0	1.0
额定功率 Kw	Rated power Kw	1.35	1.35	2.1	2.1	1.7	1.7	2.7	2.7
频率 Hz	Frequency Hz	18.7	18.7	29.6	29.6	18.7	18.7	29.6	29.6
额定转速 r/min	Rated speed r/min	280	280	444	444	280	280	444	444
额定转矩 N.m	Rated torque N.m	46	46	45	45	58	58	58	58
相数电压 V	Phase/Voltage V	1/220	3/380	1/220	3/380	1/220	3/380	1/220	3/380
额定电压 V	Rated Voltage V	167	342	158	330	170	323	140	342
电流 A	Current A	7.3	3.4	10.9	5.2	8.8	4.6	15.4	6.3
曳引轮节径 mm	Sheave dia mm	86	86	86	86	86	86	86	86
曳引带数量 NO.	Traction belt qty NO.	2	2	2	2	2	2	2	2
绝缘等级	INS.class	F	F	F	F	F	F	F	F
防护等级	IP Code	IP42	IP42	IP42	IP42	IP42	IP42	IP42	IP42
极数 P	Poles P	8	8	8	8	8	8	8	8

注: 本机需选配专用曳引带, 带扣组件, 导向轮, 另外可选配, 松闸组件, 盘车手轮组件。

Notes: GDB machine need to work with dedicated traction belt, belt lock & clip, pulley guide. Also, our hand wheel and brake release could be optional when auxiliary braking system is in need.

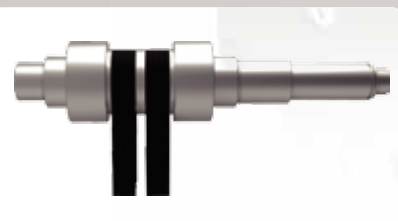

# PASSENGER Elevator Tractor

## 乘客电梯专用曳引机

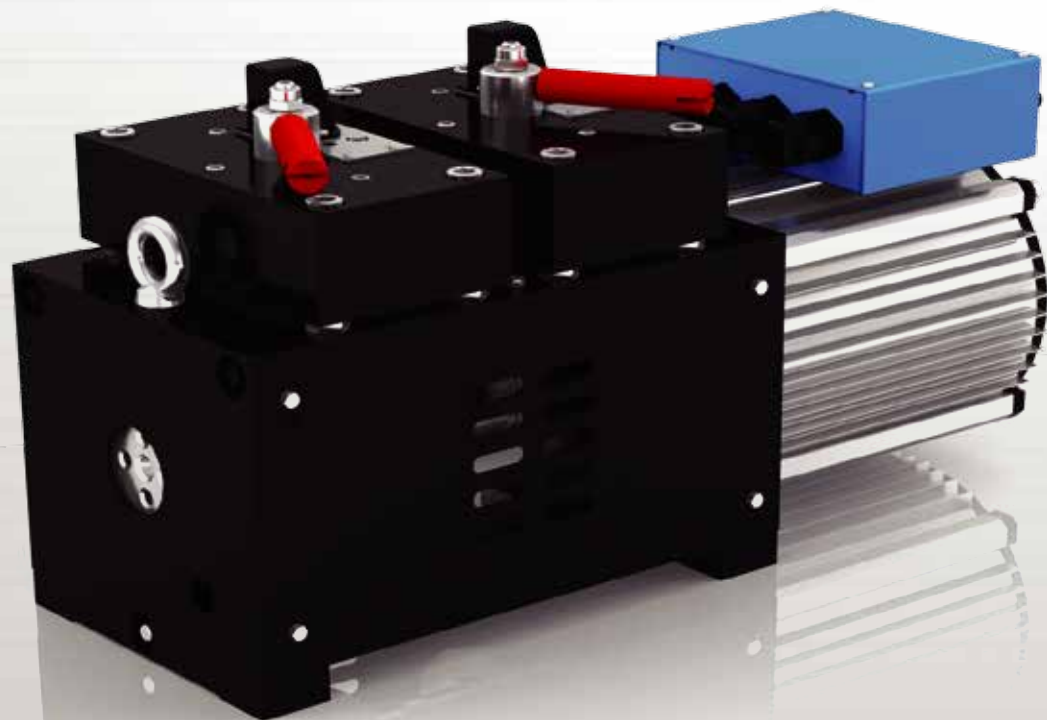

### GDB 112 - 480

载重 load: 480kg  
 电源电压 Voltage: 220 / 380V  
 悬挂比 Suspension: 2:1  
 中心高 Center Height: 112mm  
 自重 Weight: 95kg  
 最大静态载荷 Max.Static Load: 2000kg  
 制动器 Brake: DC198V 2\*0.18A  
 or DC110V 2\*0.38A

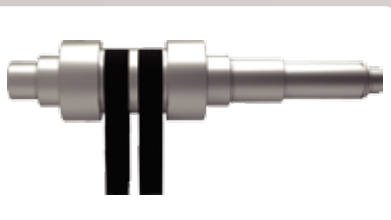

盘手车轮 (为选择项)  
 HAND WHEEL (COULD BE OPTIONAL)

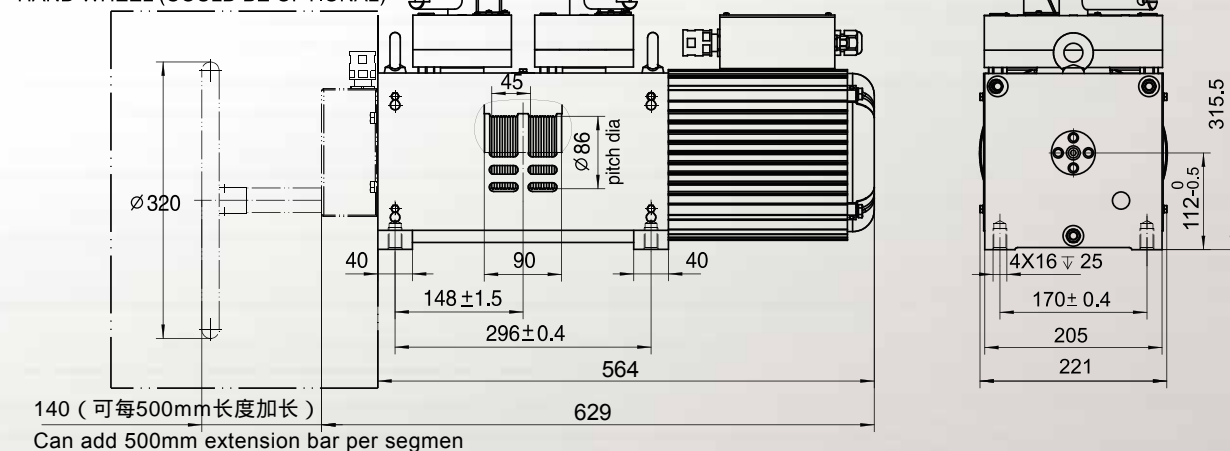

型号	TYPE	GDB112-480-4-12	GDB112-480-4-34	GDB112-480-6.3-12	GDB112-480-6.3-34	GDB112-480-10-12	GDB112-480-10-34
载重 Kg	Load capacity Kg	480	480	480	480	480	480
梯速 m/s	Lift speed m/s	0.4	0.4	0.63	0.63	1.0	1.0
额定功率 Kw	Rated power Kw	1.27	1.27	2.0	2.0	3.2	3.2
频率 Hz	Frequency Hz	11.9	11.9	18.7	18.7	29.6	29.6
额定转速 r/min	Rated speed r/min	178	178	280	280	444	444
额定转矩 N.m	Rated torque N.m	68	68	68	68	69	69
相数电压 V	Phase/Voltage V	1/220	3/380	1/220	3/380	1/220	3/380
额定电压 V	Rated Voltage V	163	308	171	330	182	332
电流 A	Current A	7.7	4.1	10.0	5.2	13.8	7.6
曳引轮节径 mm	Sheave dia mm	86	86	86	86	86	86
曳引带数量 NO.	Traction belt qty NO.	2	2	3	3	3	3
绝缘等级	INS.class	F	F	F	F	F	F
防护等级	IP Code	IP42	IP42	IP42	IP42	IP42	IP42
极数 P	Poles P	8	8	8	8	8	8

注: 1. 本机需选配专用曳引带, 带扣组件, 导向轮, 另外可选项, 松闸组件, 盘手车轮组件。

2. 480kg载重用于乘客梯时, 允许轿厢最大自重600kg, 更重轿厢可以定制三槽做法。

Notes: 1. GDB machine need to work with dedicated traction belt, belt lock & clip, pulley guide. Also, our hand wheel and brake release could be optional when auxiliary braking system is in need.

2. 480KG machine used for passenger Lift. Cabin Max allowable weight 600KG. for Cabin more than 600KG, use 3 belt machine.



# PASSENGER Elevator Tractor

## 乘客电梯专用曳引机

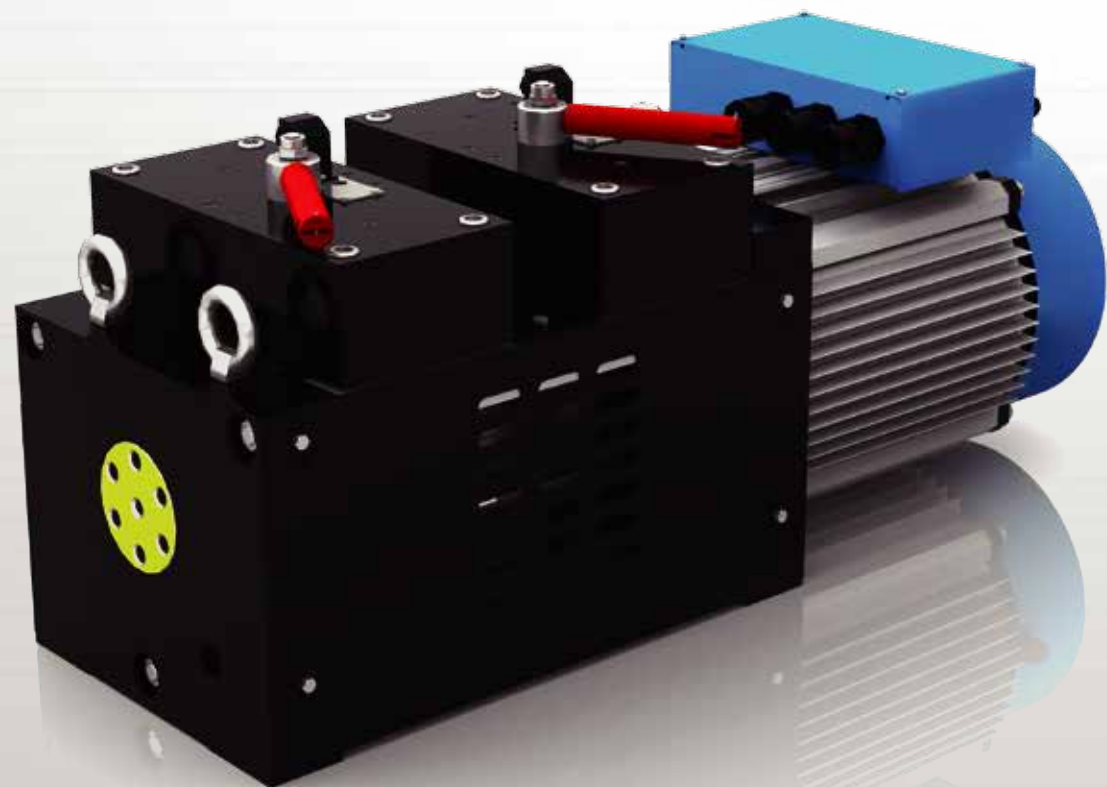

### GDB 132 - 630

载重 load: 630kg  
 电源电压 Voltage: 380V  
 悬挂比 Suspension: 2:1  
 中心高 Center Height: 132mm  
 自重 Weight: 150kg  
 最大静态载荷 Max.Static Load: 5000kg  
 制动器 Brake: DC198V 2\*0.38A  
 or DC110V 2\*0.67A

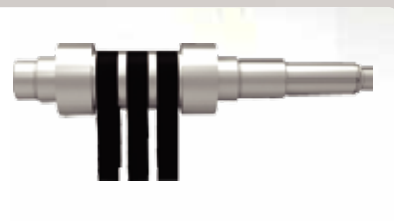

盘手车轮 (为选择项)  
 HAND WHEEL (COULD BE OPTIONAL)

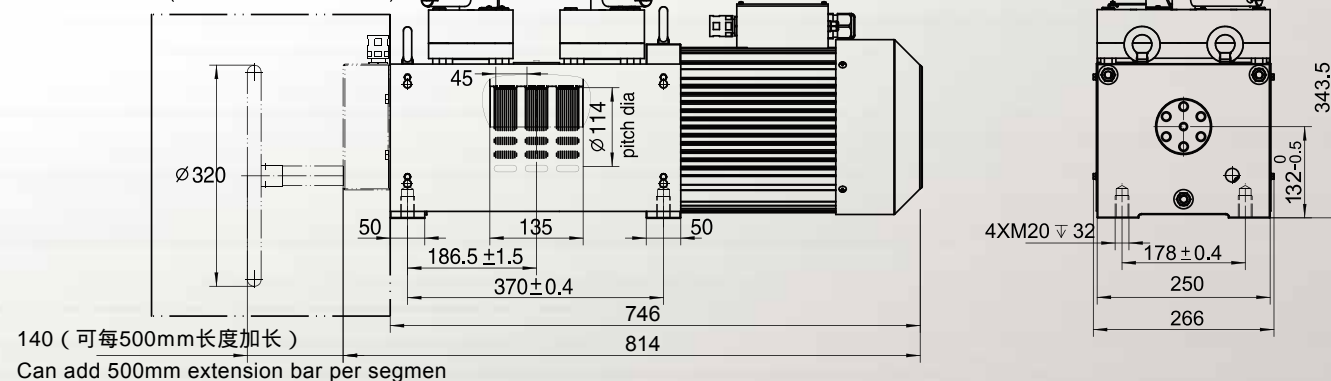

140 (可每500mm长度加长)  
 Can add 500mm extension bar per segmen

型号	TYPE	GDB132-630-6.3-12	GDB132-630-6.3-34	GDB132-630-10-12	GDB132-630-10-34	GDB132-630-16-34
载重 Kg	Load capacity Kg	630	630	630	630	630
梯速 m/s	Lift speed m/s	0.63	0.63	1.0	1.0	1.6
额定功率 Kw	Rated power Kw	2.7	2.7	4.2	4.2	6.8
频率 Hz	Frequency Hz	21.1	21.1	33.5	33.5	53.6
额定转速 r/min	Rated speed r/min	211	211	335	335	536
额定转矩 N.m	Rated torque N.m	122	122	120	120	121
相数电压 V	Phase/Voltage V	1/220	3/380	1/220	3/380	3/380
额定电压 V	Rated Voltage V	175	329	172	319	323
电流 A	Current A	13.0	6.9	18.7	10.0	15.2
曳引轮节径 mm	Sheave dia mm	114	114	114	114	114
曳引带数量 NO.	Traction belt qty NO.	3	3	3	3	3
绝缘等级	INS.class	F	F	F	F	F
防护等级	IP Code	IP42	IP42	IP42	IP42	IP42
极数 P	Poles P	12	12	12	12	12

注: 本机需选配专用曳引带, 带扣组件, 导向轮, 另外可选配, 松闸组件, 盘车手轮组件。  
 Notes: GDB machine need to work with dedicated traction belt, belt lock & clip, pulley guide. Also, our hand wheel and brake release could be optional when auxiliary braking system is in need.

# PASSENGER Elevator Tractor

## 乘客电梯专用曳引机

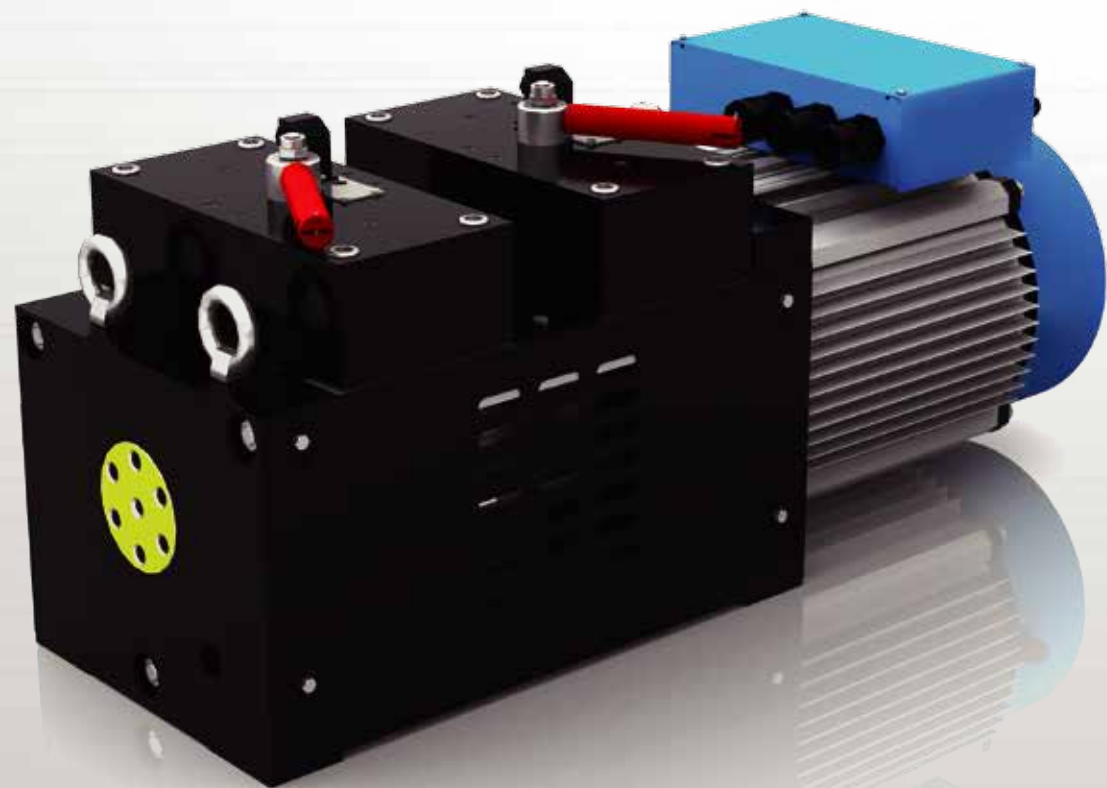

### GDB 132 - 800

载重 load: 800kg  
 电源电压 Voltage: 380V  
 悬挂比 Suspension: 2:1  
 中心高 Center Height: 132mm  
 自重 Weight: 165kg  
 最大静态载荷 Max.Static Load: 5000kg  
 制动器 Brake: DC198V 2\*0.38A  
 or DC110V 2\*0.67A

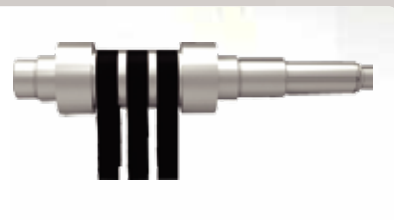

盘手车轮 (为选择项)  
 HAND WHEEL (COULD BE OPTIONAL)

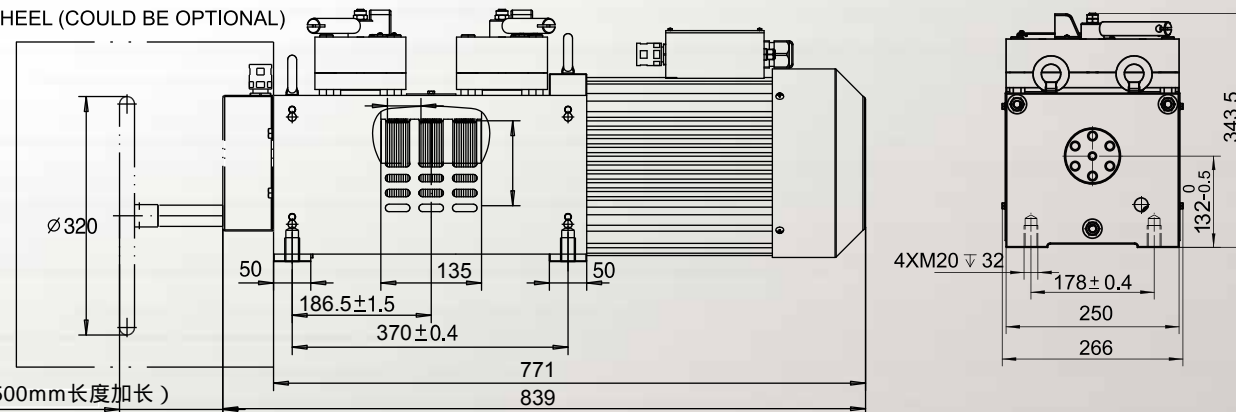

140 (可每500mm长度加长)  
 Can add 500mm extension bar per segmen

型号	TYPE	GDB132-800-10-34	GDB132-800-16-34	GDB132-800-17.5-34	GDB132-800-20-34
载重 Kg	Load capacity Kg	800	800	800	800
梯速 m/s	Lift speed m/s	1.0	1.6	1.75	2.0
额定功率 Kw	Rated power Kw	5.4	8.6	9.4	10.7
频率 Hz	Frequency Hz	33.5	53.6	58.6	67.0
额定转速 r/min	Rated speed r/min	335	536	586	670
额定转矩 N.m	Rated torque N.m	154	153	153	153
相数电压 V	Phase/Voltage V	3/380	3/380	3/380	3/380
额定电压 V	Rated Voltage V	323	321	331	338
电流 A	Current A	12.6	19.2	20.1	22.3
曳引轮节径 mm	Sheave dia mm	114	114	114	114
曳引带数量 NO.	Traction belt qty NO.	3	3	3	3
绝缘等级	INS.class	F	F	F	F
防护等级	IP Code	IP42	IP42	IP42	IP42
极数 P	Poles P	12	12	12	12

注: 本机需选配专用曳引带, 带扣组件, 导向轮, 另外可选配, 松闸组件, 盘手车轮组件。  
 Notes: GDB machine need to work with dedicated traction belt, belt lock & clip, pulley guide. Also, our hand wheel and brake release could be optional when auxiliary braking system is in need.



# PASSENGER Elevator Tractor

## 乘客电梯专用曳引机

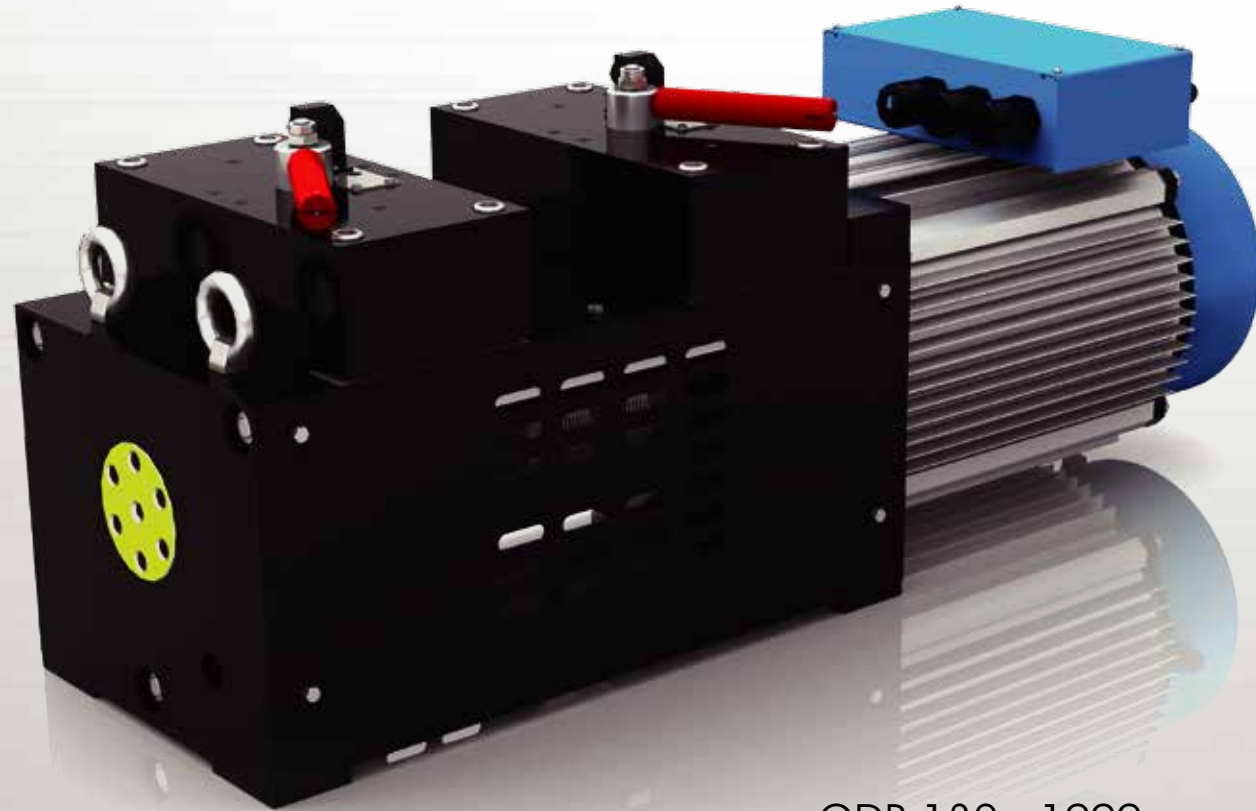

### GDB 132 - 1000

载重 load: 1000kg  
 电源电压 Voltage: 380V  
 悬挂比 Suspension: 2:1  
 中心高 Center Height: 132mm  
 自重 Weight: 170kg  
 最大静态载荷 Max.Static Load: 5000kg  
 制动器 Brake: DC198V 2\*0.38A  
 or DC110V 2\*0.67A

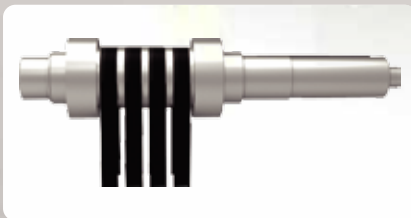

盘手车轮 (为选择项)

HAND WHEEL (COULD BE OPTIONAL)

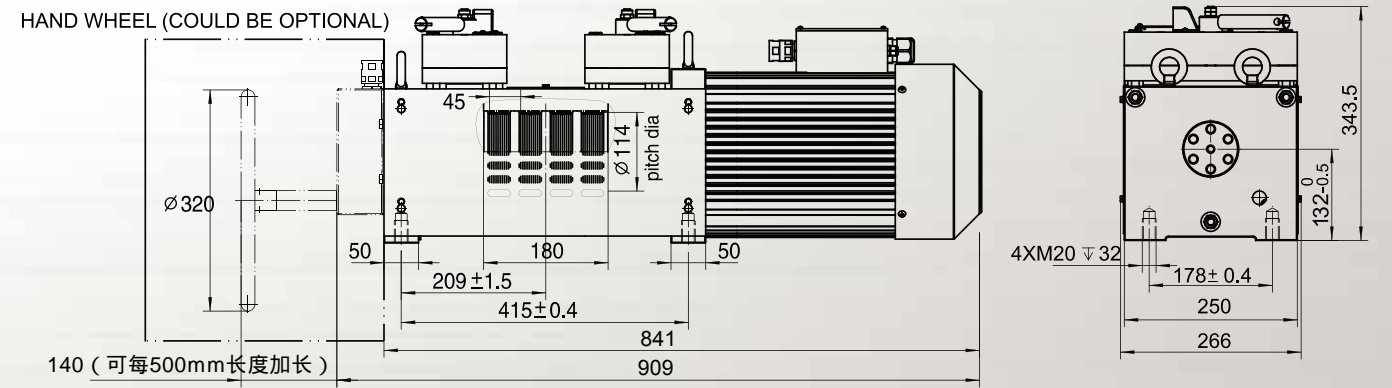

型号	TYPE	GDB132-1000-10-34	GDB132-1000-16-34	GDB132-1000-17.5-34	GDB132-1000-20-34	GDB132-1000-25-34
载重 Kg	Load capacity Kg	1000	1000	1000	1000	1000
梯速 m/s	Lift speed m/s	1.0	1.6	1.75	2.0	2.5
额定功率 Kw	Rated power Kw	6.7	10.7	11.7	13.4	16.8
频率 Hz	Frequency Hz	33.5	53.6	58.6	67.0	83.8
额定转速 r/min	Rated speed r/min	335	536	586	670	838
额定转矩 N.m	Rated torque N.m	191	191	191	191	192
相数电压 V	Phase/Voltage V	3/380	3/380	3/380	3/380	3/380
额定电压 V	Rated Voltage V	324	328	316	335	331
电流 A	Current A	15.5	23.2	26.2	28.0	35.0
曳引轮节径 mm	Sheave dia mm	114	114	114	114	114
曳引带数量 NO.	Traction belt qty NO.	4	4	4	4	4
绝缘等级	INS.class	F	F	F	F	F
防护等级	IP Code	IP42	IP42	IP42	IP42	IP42
极数 P	Poles P	12	12	12	12	12

注：1. 本机需选配专用曳引带，带扣组件，导向轮，另外可选配，松闸组件，盘车手轮组件。  
 2. 若轿厢自重低于1150kg，可使用3根钢带。

Notes: 1. GDB machine need to work with dedicated traction belt,belt lock& clip,pulley guide.Also,our hand wheel and brake release could be optional when auxiliary braking system is in need.  
 2. If cabin weight below 1150KG, could use 3 belt.

# PASSENGER Elevator Tractor

## 乘客电梯专用曳引机



### GDB 132 - 1250

载重 load: 1250kg  
 电源电压 Voltage: 380V  
 悬挂比 Suspension: 2:1  
 中心高 Center Height: 132mm  
 自重 Weight: 190kg  
 最大静态载荷 Max.Static Load: 5000kg  
 制动器 Brake: DC198V 2\*0.38A  
 or DC110V 2\*0.67A



盘手车轮 (为选择项)

HAND WHEEL (COULD BE OPTIONAL)

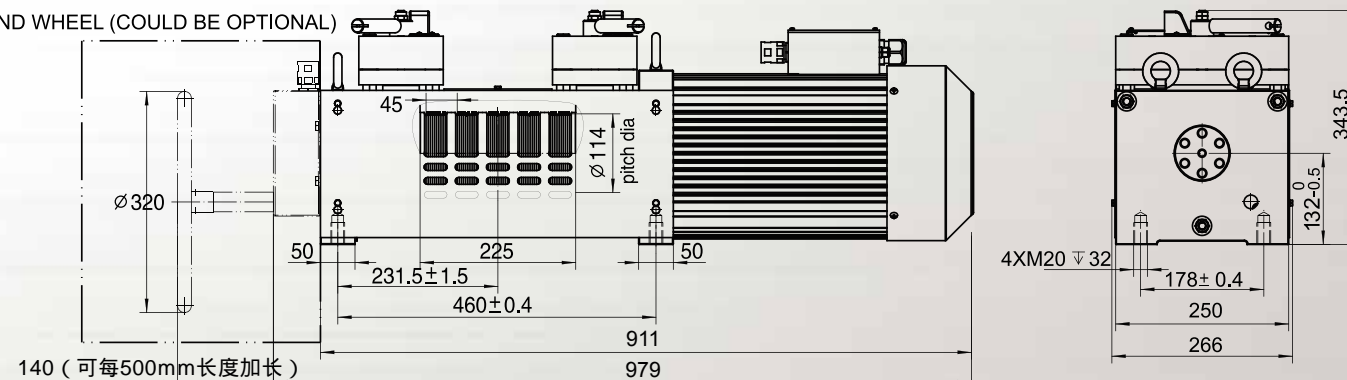

140 (可每500mm长度加长)  
 Can add 500mm extension bar per segmen

型号	TYPE	GDB132-1250-10-34	GDB132-1250-16-34	GDB132-1250-17.5-34	GDB132-1250-20-34	GDB132-1250-25-34
载重 Kg	Load capacity Kg	1250	1250	1250	1250	1250
梯速 m/s	Lift speed m/s	1.0	1.6	1.75	2.0	2.5
额定功率 Kw	Rated power Kw	8.4	13.4	14.7	16.8	20.9
频率 Hz	Frequency Hz	33.5	53.6	58.6	67.0	83.8
额定转速 r/min	Rated speed r/min	335	536	586	670	838
额定转矩 N.m	Rated torque N.m	239	239	240	239	238
相数电压 V	Phase/Voltage V	3/380	3/380	3/380	3/380	3/380
额定电压 V	Rated Voltage V	323	319	324	340	322
电流 A	Current A	19.6	30.0	32.2	34.7	44.9
曳引轮节径 mm	Sheave dia mm	114	114	114	114	114
曳引带数量 NO.	Traction belt qty NO.	5	5	5	5	5
绝缘等级	INS.class	F	F	F	F	F
防护等级	IP Code	IP42	IP42	IP42	IP42	IP42
极数 P	Poles P	12	12	12	12	12

注：本机需选配专用曳引带，带扣组件，导向轮，另外可选配，松闸组件，盘手车轮组件。

Notes: GDB machine need to work with dedicated traction belt,belt lock & clip,pulley guide.Also,our hand wheel and brake release could be optional when auxiliary braking system is in need.



# PASSENGER Elevator Tractor

## 乘客电梯专用曳引机



### GDB 132 - 1600

载重 load: 1600kg  
 电源电压 Voltage: 380V  
 悬挂比 Suspension: 2:1  
 中心高 Center Height: 132mm  
 自重 Weight: 205kg  
 最大静态载荷 Max.Static Load: 5000kg  
 制动器 Brake: DC198V 2\*0.64A  
 or DC110V 2\*0.98A

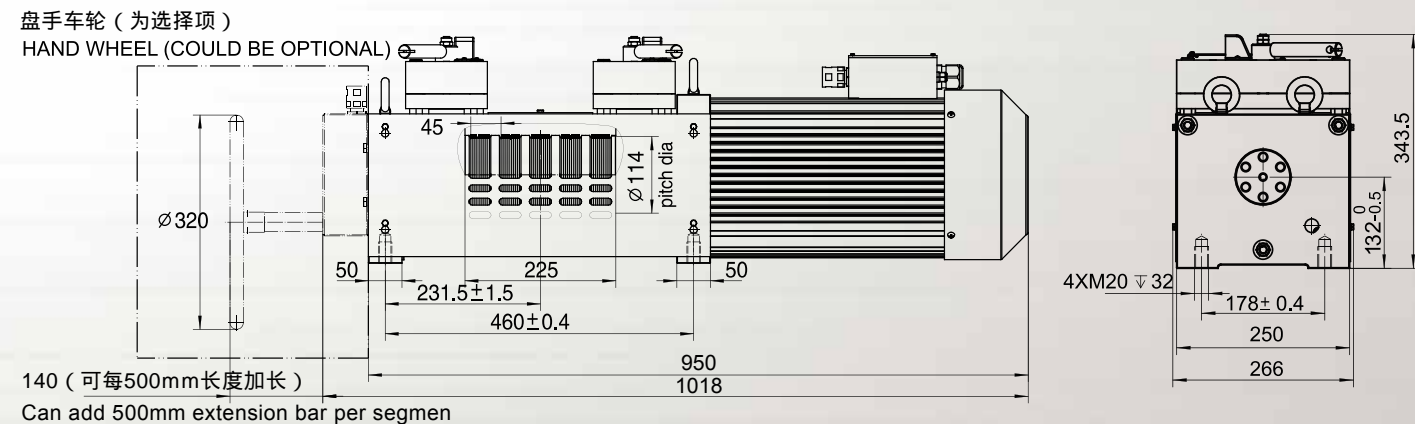

型号	TYPE	GDB132-1600-10-34	GDB132-1600-16-34	GDB132-1600-17.5-34	GDB132-1600-20-34	GDB132-1600-25-34
载重 Kg	Load capacity Kg	1600	1600	1600	1600	1600
梯速 m/s	Lift speed m/s	1.0	1.6	1.75	2.0	2.5
额定功率 Kw	Rated power Kw	10.7	17.2	18.8	21.4	26.8
频率 Hz	Frequency Hz	33.5	53.6	58.6	67.0	83.8
额定转速 r/min	Rated speed r/min	335	536	586	670	838
额定转矩 N.m	Rated torque N.m	305	306	306	305	306
相数电压 V	Phase/Voltage V	3/380	3/380	3/380	3/380	3/380
额定电压 V	Rated Voltage V	336	332	334	314	349
电流 A	Current A	24.0	37.1	40.2	48.0	53.4
曳引轮节径 mm	Sheave dia mm	114	114	114	114	114
曳引带数量 NO.	Traction belt qty NO.	5	5	5	5	5
绝缘等级	INS.class	F	F	F	F	F
防护等级	IP Code	IP42	IP42	IP42	IP42	IP42
极数 P	Poles P	12	12	12	12	12

注：本机需选配专用曳引带，带扣组件，导向轮，另外可选配，松闸组件，盘车手轮组件。  
 Notes: GDB machine need to work with dedicated traction belt,belt lock & clip,pulley guide.Also,our hand wheel and brake release could be optional when auxiliary braking system is in need.

# PASSENGER Elevator Tractor

## 乘客电梯专用曳引机

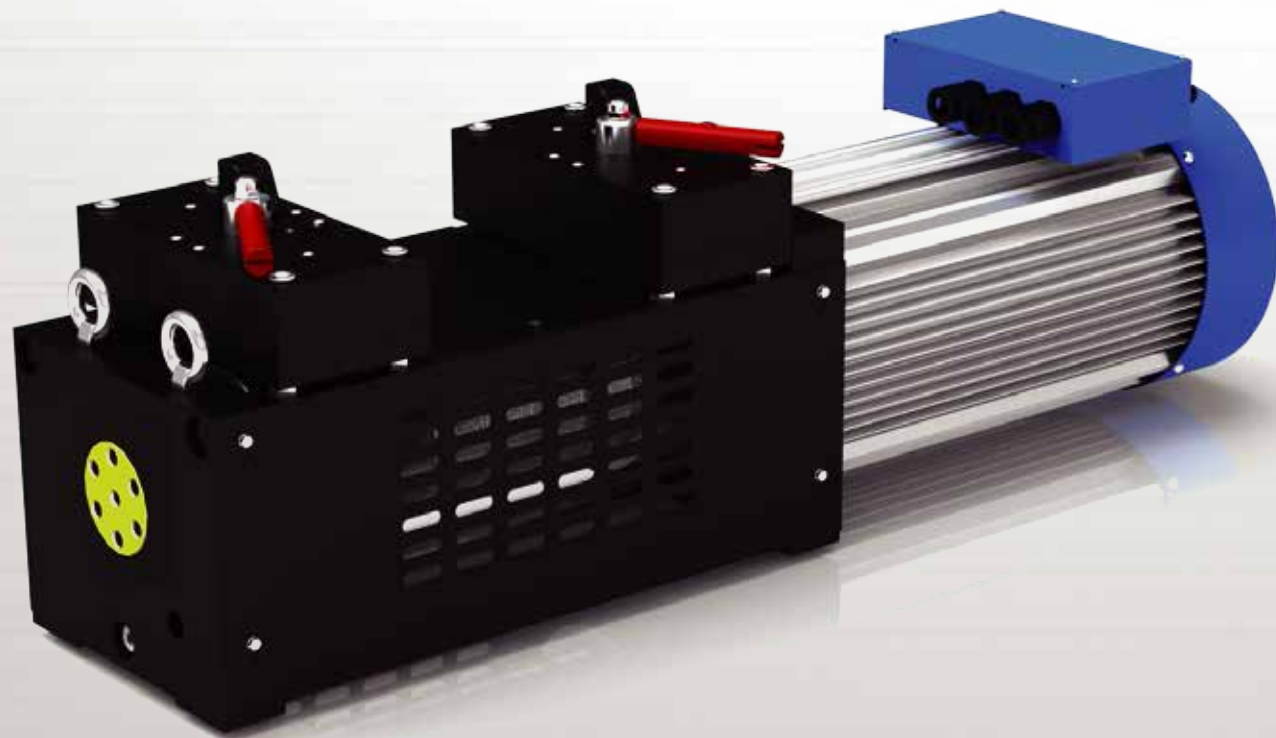

### GDB 132 - 2000

载重 load: 2000kg  
 电源电压 Voltage: 380V  
 悬挂比 Suspension: 2:1  
 中心高 Center Height: 132mm  
 自重 Weight: 220kg  
 最大静态载荷 Max.Static Load: 5000kg  
 制动器 Brake: DC198V 2\*0.64A  
 or DC110V 2\*0.98A



盘手车轮 (为选择项)

HAND WHEEL (COULD BE OPTIONAL)

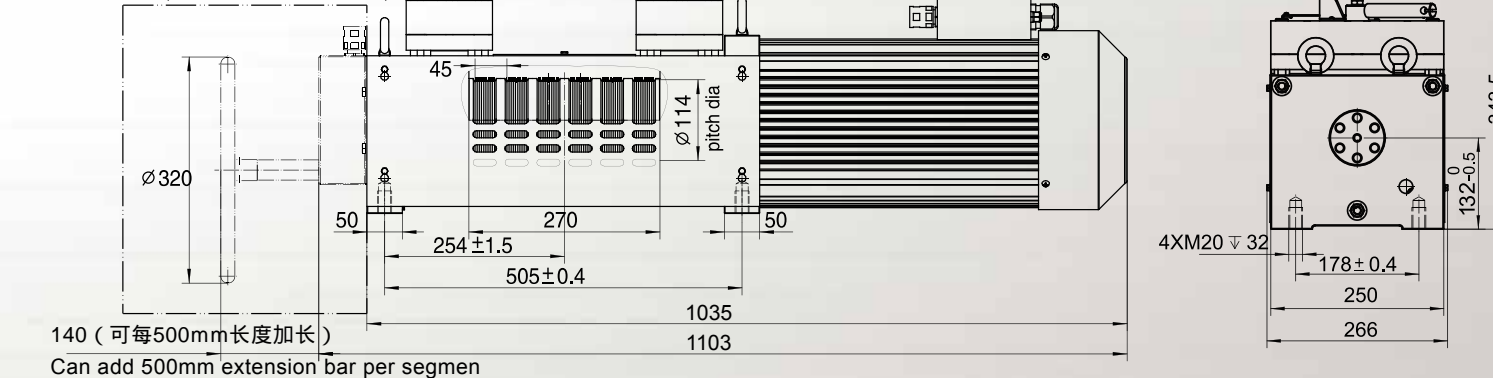

型号	TYPE	GDB132-2000-10-34	GDB132-2000-16-34	GDB132-2000-17.5-34	GDB132-2000-20-34	GDB132-2000-25-34
载重 Kg	Load capacity Kg	2000	2000	2000	2000	2000
梯速 m/s	Lift speed m/s	1.0	1.6	1.75	2.0	2.5
额定功率 Kw	Rated power Kw	13.4	21.4	23.5	26.8	33.5
频率 Hz	Frequency Hz	33.5	53.6	58.6	67.0	83.8
额定转速 r/min	Rated speed r/min	335	536	586	670	838
额定转矩 N.m	Rated torque N.m	382	381	383	382	382
相数电压 V	Phase/Voltage V	3/380	3/380	3/380	3/380	3/380
额定电压 V	Rated Voltage V	341	335	331	337	323
电流 A	Current A	29.8	45.9	50.7	56.3	72.3
曳引轮节径 mm	Sheave dia mm	114	114	114	114	114
曳引带数量 NO.	Traction belt qty NO.	6	6	6	6	6
绝缘等级	INS.class	F	F	F	F	F
防护等级	IP Code	IP42	IP42	IP42	IP42	IP42
极数 P	Poles P	12	12	12	12	12

注：本机需选配专用曳引带，带扣组件，导向轮，另外可选配，松闸组件，盘车手轮组件。

Notes: GDB machine need to work with dedicated traction belt,belt lock& clip,pulley guide.Also,our hand wheel and brake release could be optional when auxiliary braking system is in need.





**01** 曳引机  
Traction Machine GDB132-1000-20-34-XX

**GDB**   **132** - **1000** - **20** - **34** - **XX**

Series No    Center Height    Loading capacity    Speed    Voltage    Additional code  
系列名    中心高    机器载重    速度    电压    附加代码



**02** 盘车手轮  
Hand Wheel XP-H11205

**XP** - **H**    **112**    **05**

Series No    Hand Wheel    Center Height    Extension Bar Length Code  
系列名    盘车手轮    中心高    接长杆长度代码

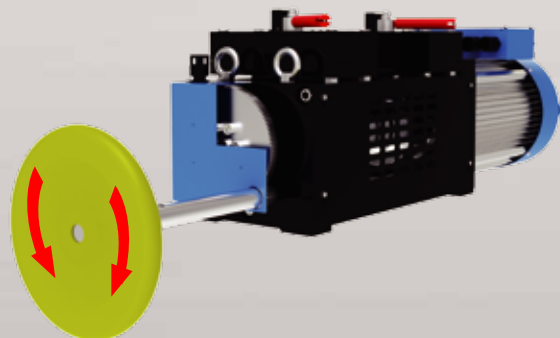
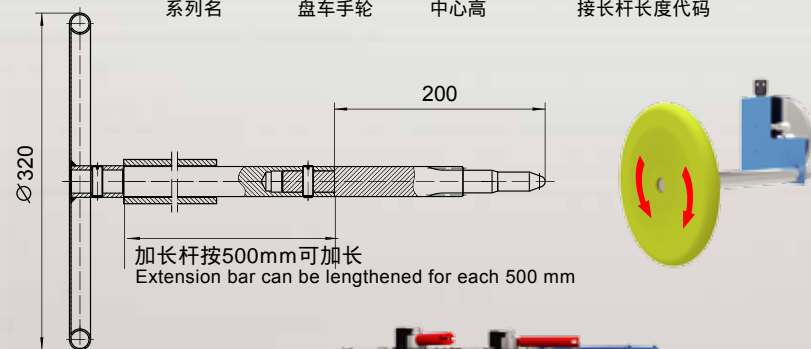

**03** 松闸组件  
Brake Release XP-BRB280

**XP** - **BR**    **B2**    **80**

Series No    Brake Release    Belt Number    Wire Length Code  
系列名    松闸组件    曳引带数量    钢丝绳长度代码

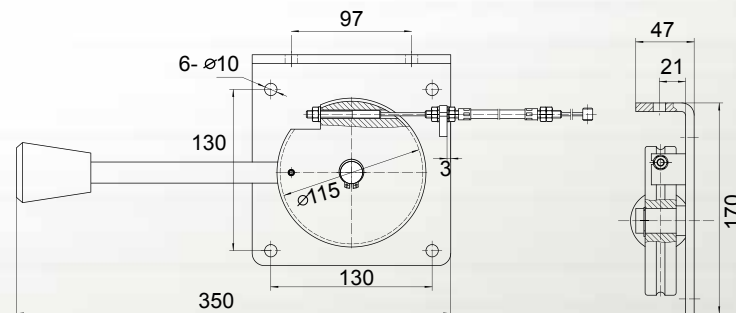

**04** 绳头  
Belt Lock XP-L3012

**XP** - **L**    **30**    **12**

Series No    Belt Lock    Belt Width    Max Hoist Height  
系列名    绳头    适配的曳引带宽度    最大提升高度

HOISTING HEIGH 提升高度	L
$H \leq 12m$	408
$12m \leq H \leq 20m$	432
$20m \leq H \leq 50m$	482
$50m \leq H \leq 80m$	532

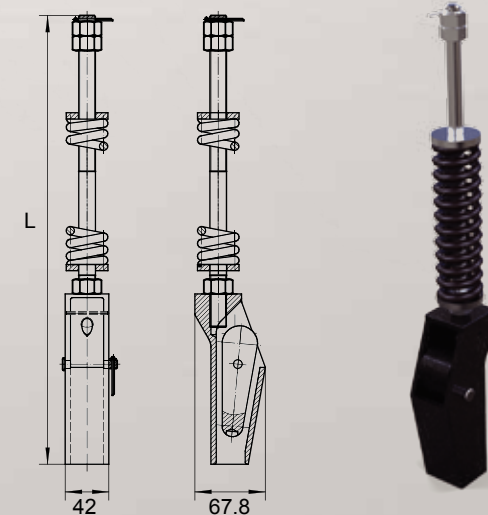

**05** 曳引带端扣  
Belt Clip XP-BC30

**XP** - **BC**    **30**

Series No    Belt Clip    Belt Width  
系列名    曳引带端扣    适配的曳引带宽度

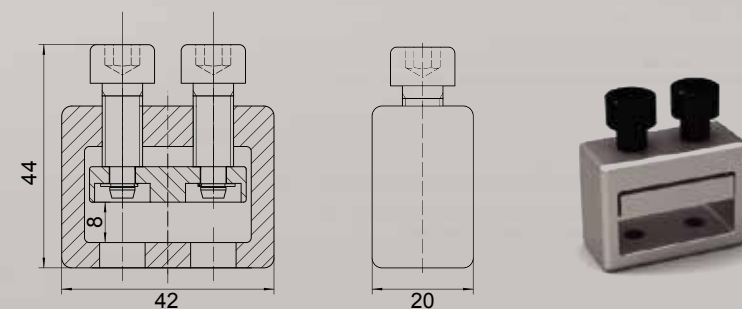

**GU DA BELT  
TRACTION  
SOLUTION**  
谷达钢带系统解决方案

# 06 曳引带 (专用) XP-B30

Traction Belt

**XP - B 30N**  
 Series No 系列名    Traction Belt 曳引带    Center Height 适配的曳引带宽度

Clad Material: Hi-strength (TPU)  
 覆层材料: 高强度(聚氨酯)

Provide protection from rust.  
 提供防护避免锈蚀

Alleviate noise and friction when geared in  
 Slighter friction with metallic sheave.  
 啮合时减少摩擦噪音, 避免金属的直接摩擦

Disuse lubricant in maintenance  
 维护时无需润滑

Expanded service life.  
 更长的使用寿命

Minumum Breaking Force 43000N  
 最小破断拉力43000N



Improvement in structure and re - group 整体结构的提升



Much longer Working life 更长的使用寿命  
 After 10 million times of fatigue strength test, the breaking force with 5% decline than original.  
 1000万次疲劳强度测试后, 破断拉力下降5%

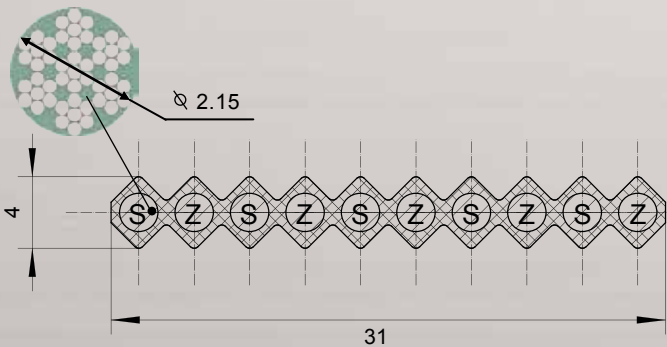

# 07 导带轮 XP-GWB3XX

Guide Wheel

**XP - GW B3 XX**  
 Series No 系列名    Guide Wheel 导带轮    Belt Number 曳引带数量    Special Code 特殊代码

PART NO. 货号	X - 曳引带数	L1	L2
XP-GW B2	2	150	104
XP-GW B3	3	195	149
XP-GW B4	4	240	194
XP-GW B5	5	285	239
XP-GW B6	6	330	284

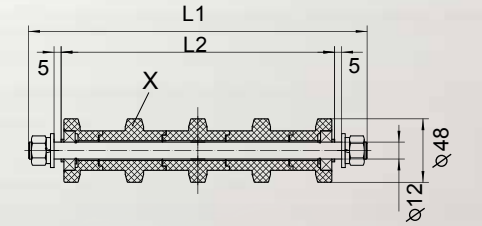

# 08 反向轮 XP-CP132B3XX

Counter Pulley

**XP - CP 132 B3 XX**  
 Series No 系列名    Counter Pulley 反向轮    Counter pulley external Dia 反向轮外径    Belt Number 曳引带数量    Special Code 特殊代码

Counter Pulley Set-112 Series

PART NO. 货号	QTY 曳引带数	L
XP-CP 90 B2	2	123
XP-CP 90 B3	3	168

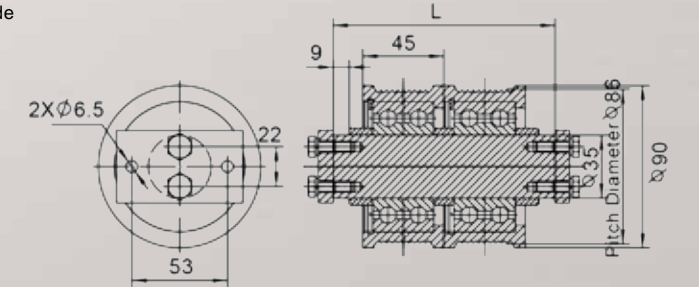

Counter Pulley Set-132 Series

PART NO. 货号	QTY 曳引带数	L
XP-CP 132 B2	2	125
XP-CP 132 B3	3	170
XP-CP 132 B4	4	215
XP-CP 132 B5	5	260
XP-CP 132 B6	6	305

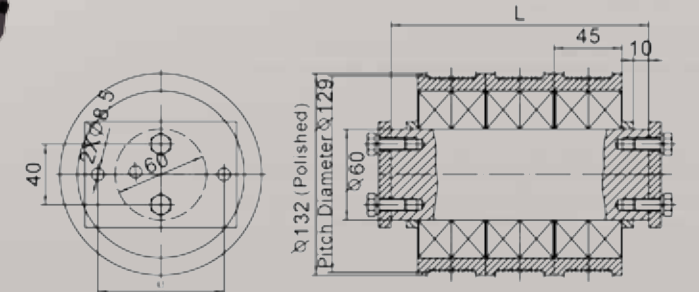



# 09 断带检测 Belt Breaking Detect

XP-D30C2

**XP - D**   **30**   **C**   **2**  
 Series No   Belt Breaking Detect   Belt Width   Short circuit blade+ test blade+junction box   Belt Number  
 系列名   断带检测装置   适配的曳引带宽度   短路刀+测试刀+接线盒   曳引带数

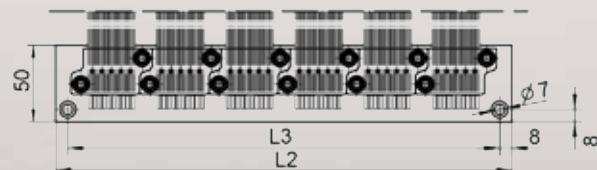
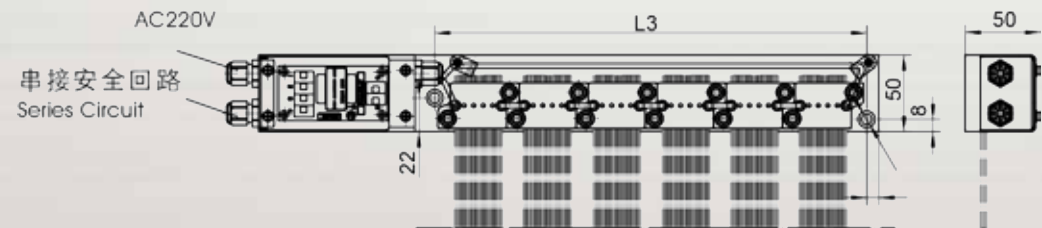
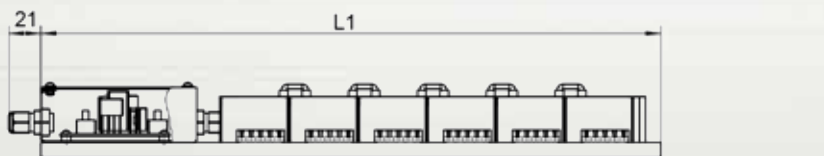

PART NO.货号	QTY曳引带数	L1	L2	L3
XP-D 30 C2	2	225	118	102
XP-D 30 C3	3	270	163	147
XP-D 30 C4	4	315	208	192
XP-D 30 C5	5	360	253	237
XP-D 30 C6	6	405	298	282

## 有线检测端安装示意图

Wire Monitor side Install Sketch

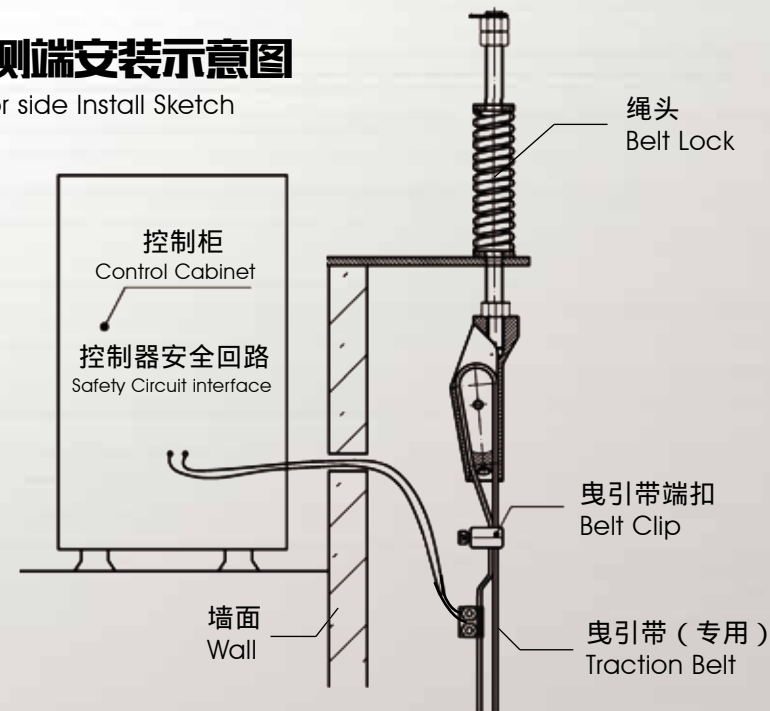

## 无线短路端安装示意图

Short Circuit Side Install Sketch

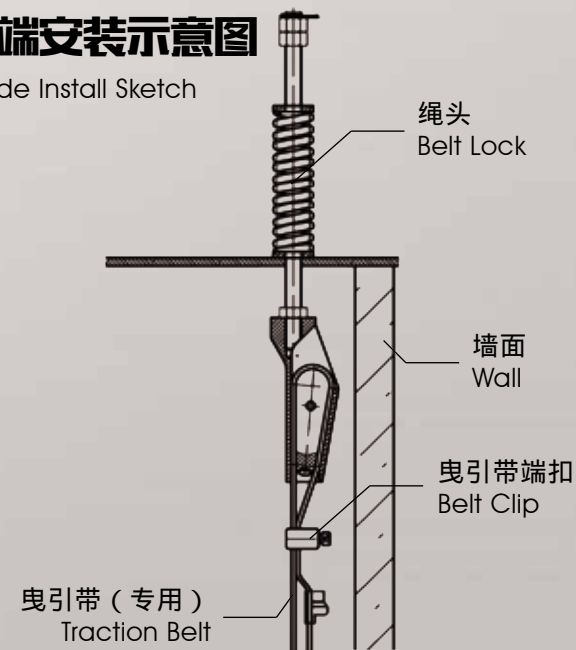

# WRAP ANGLE ILLUSTRATION 包角结构说明

\* Wrap Angle design from 95 - 180 is allowed

\* 允许从95°到180°的包角设计

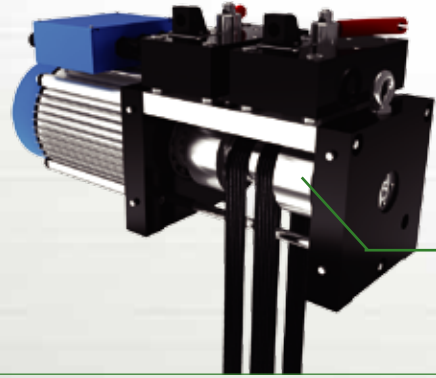

WRAP ANGLE 180°  
包角180度

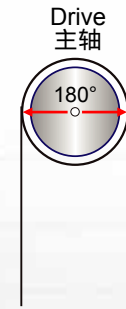

MAX

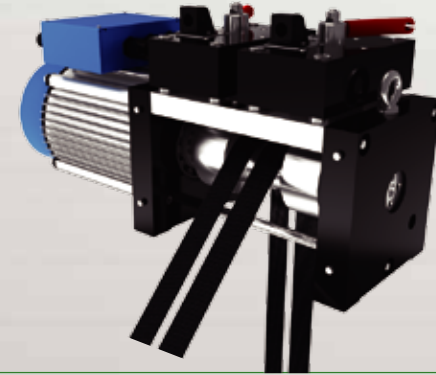

Drive 主轴



Counter Pulley  
反向轮

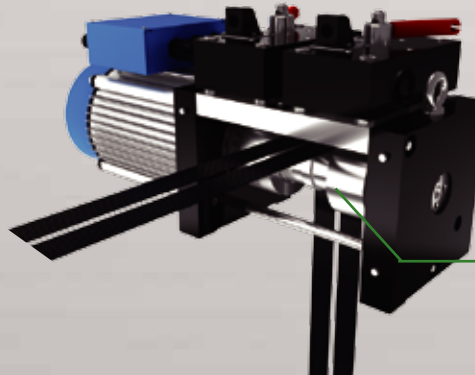

WRAP ANGLE 95°  
包角95度

Drive 主轴

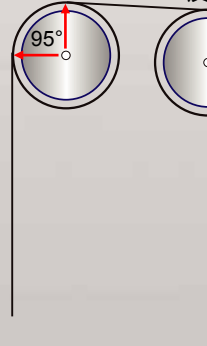

Counter Pulley  
反向轮

MIN

A series of horizontal dashed lines for writing notes.